

■ Balcony Complete Drain with frostproof odour trap



The balcony complete drain DN 50/DN 40 vertical or horizontal

suited **perfectly for balcony and terrace:**

- frostproof odour trap made of EPDM
- height-adjustable inlet grate made of stainless steel
- Clamp flange made of stainless steel for the secure clamping of roofing surfaces of all kinds
- Feet for simple positioning, e. g. for screed construction
- Inlet opportunity at drainage level
- Vertical or horizontal drain

Installation example balcony complete drain

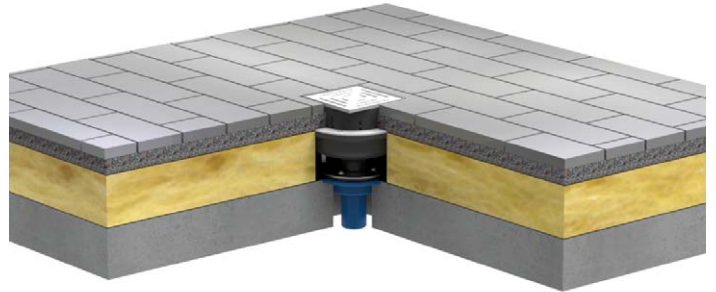

Built-in balcony drain DN 50 as basic element and slip on balcony complete drain DN 50 as extension element installed in a insulated roof. The height-adjustable inlay grate serves as an edge to the tiled surface.

Technical data balcony complete drain

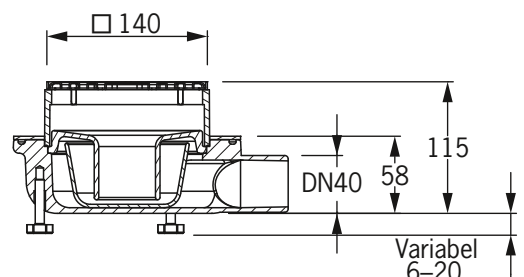
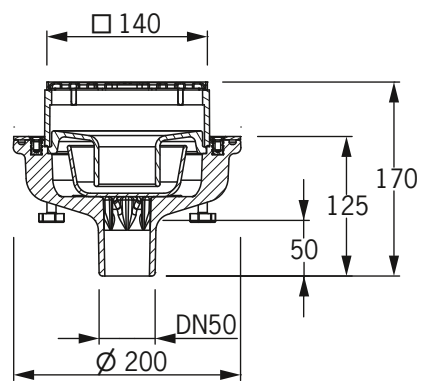

Dimension | Art. No.

Balcony complete drain vertical

DN 50 **2501**

Balcony complete drain horizontal

DN 40 **2502**

Extension ring made of PUR

for the heightening up to 10 cm, can be stacked

2509

