

■ Collar Drain DN 150 with adhesive collar

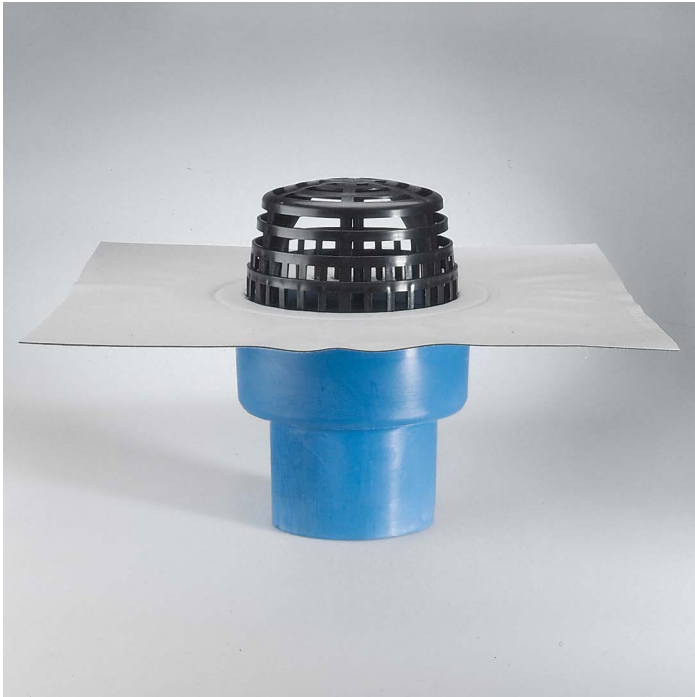

Collar drain made of PUR

heat insulated, CFC-free, with pebble trap and foam-filled connection collar (Bitumen, ECB, PVC or special foil).

Also heatable via an integrated, self-regulating 230 V PTC heating element, performance up to max. 10 W. We recommend using the frost switch base set (Art.-No. 5922, see page 73) in connection with our heatable drains.

Extension element with connection collar and anti-back flow seal, suitable for all compact collar drains..

Installation example Collar drain DN 150

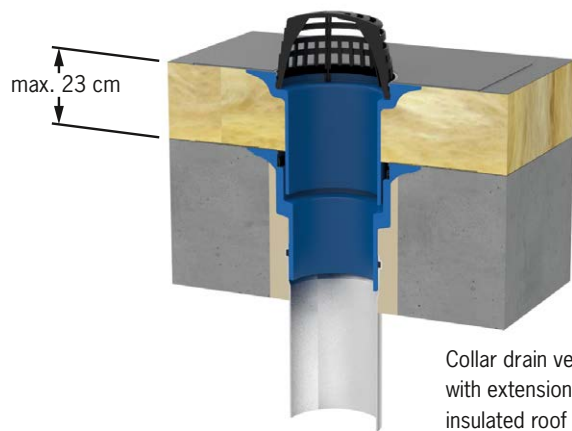

Collar drain vertical DN 150 with extension element in an insulated roof

Securing groove + pebble trap = secure pebble collection

The securing groove ensures that the connection between the body of the drain and the pebble trap is permanently secure

Securing groove + Anti-backflow seal = Secure backflow prevention

If base elements and extensions are used, as in e.g. insulated roofs, then the securing groove of the base element would be connected with the anti-backflow seal. The anti-backflow seal, which was specially developed for the collar drain, can be securely fastened to the securing groove.

If the extension element is fitted into the base element, backflow prevention is provided.

The seal can not slip during this process as the seal always sits correctly.

Technical data Collar drain DN 150

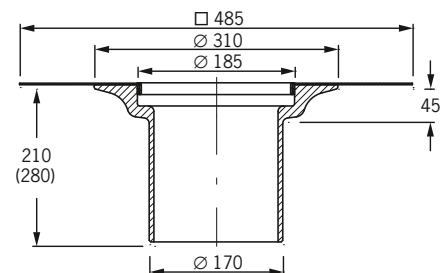
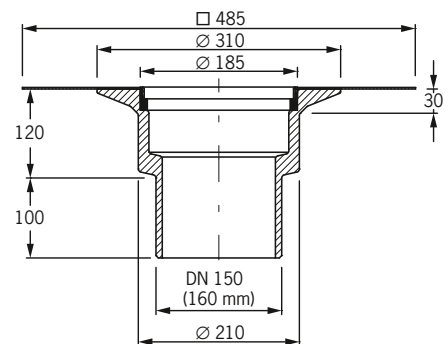

Art. No	Drainage capacity*
3008, 3028.2	9,5 l/s (45 mm)

Image	Dimension Art. No.
	Collar drain made of PUR vertical: DN 150 3008
	Collar drain made of PUR vertical heatable (230V, cable length 0.8 m): DN 150 3028.2
	Extension element made of PUR up to 16 cm 3081 up to 23 cm 3083

*Drainage capacity acc. to DIN EN 12532 in l/sec (accumulation height in millimeters)