

■ Compact Collar Drain

The value for money solution



Compact collar drain vertical, shown here with Wolflin collar

Compact collar drain made of PUR

heat insulated, CFC-free, with pebble trap and foam-filled connection collar (Bitumen, ECB, PVC or special foil). **Also heatable** via an integrated, self-regulating 230 V PTC heating element, performance up to max. 10 W. We recommend using the frost switch base set (Art.-No. 5922, see page 73) in connection with our heatable drains.

Extension element with feeder line and anti-backflow seal, suitable for all compact collar drains and universal drains.

The compact collar drain:

- with large adhesive collar
- adhesive collar made of bitumen, PVC- or special foil
- fully heat insulated
- extensive accessory range, e.g. terrace construction sets, pebble ring with lid etc.
- made of CFC-free PUR-Integral hard foam
- quality controlled production process in acc. with DIN 1253

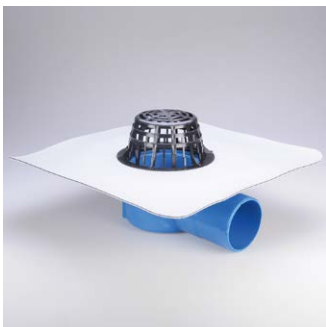

Compact collar drain horizontal – particularly low construction height!



Extension element, available for insulating material up to a thickness of 35 cm.



The compact-collar drain DN 70/DN 100/DN 125 is available in both vertical and horizontal variations as a **heatable drain**.

Heating is provided via a self-regulating PTC*heating element 230 V. That keeps everything ice-free even at extreme temperatures.

We recommend using the frost switch base set (Art.-No. 5922, see page 73) in connection with our heatable drains.

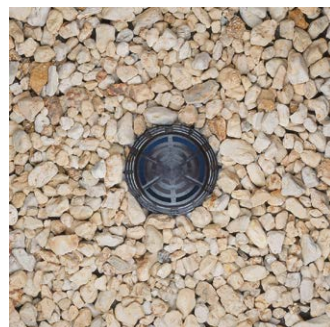
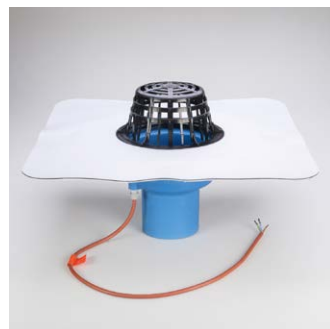

Drain with pebble trap in a flat roof

Installation example Compact collar drain

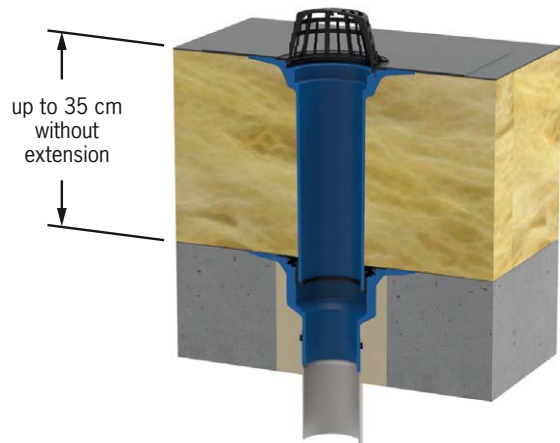

Compact collar drain vertical DN 100 with extension element in an insulated roof

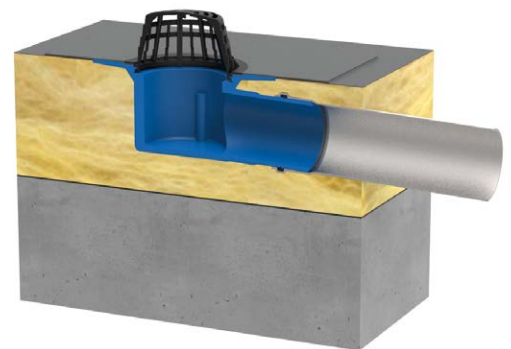

Compact collar drain horizontal DN 100 in an insulated roof

Dimension | Art. No.



Compact collar drain (PUR)
vertical:
DN 70 **3102**
DN 100 **3104**
DN 125 **3106**

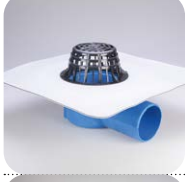

horizontal:
DN 70 **3112**
DN 100 **3114**
DN 125 **3115**



Compact collar drain (PUR)
vertical, **heatable** (230V,
cable length 0.8m):
DN 70 **3122.2**
DN 100 **3124.2**
DN 125 **3126.2**



horizontal, **heatable** (230V,
cable length 0.8m):
DN 70 **3132.2**
DN 100 **3134.2**
DN 125 **3136.2**

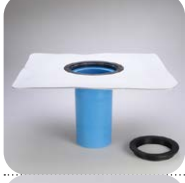

Extension element (PUR)
up to 16 cm **3181**
up to 23 cm **3183**
up to 35 cm **3185**



**Insulation piece for
extension elements**
2188

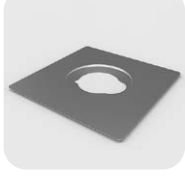

Collar plate
2189
suitable for the Universal or
compact collar range, shaped to
integrate the drain even with the
surface

Art.-No.	Nominal-Ø	Actual-Ø	H	Drainage capacity*
Compact collar drains, vertical				
3102, 3122.2	DN 70	75		6,3 l/s (35 mm)
3104, 3124.2	DN 100	110		6,8 l/s (35 mm)
3106, 3126.2	DN 125	125		8,7 l/s (45 mm)
Compact collar drains, horizontal				
3112, 3132.2	DN 70	75	105	5,8 l/s (35 mm)
3114, 3134.2	DN 100	110	140	6,1 l/s (35 mm)
3115, 3136.2	DN 125	125	160	8,5 l/s (45 mm)

Installation example Compact collar drains

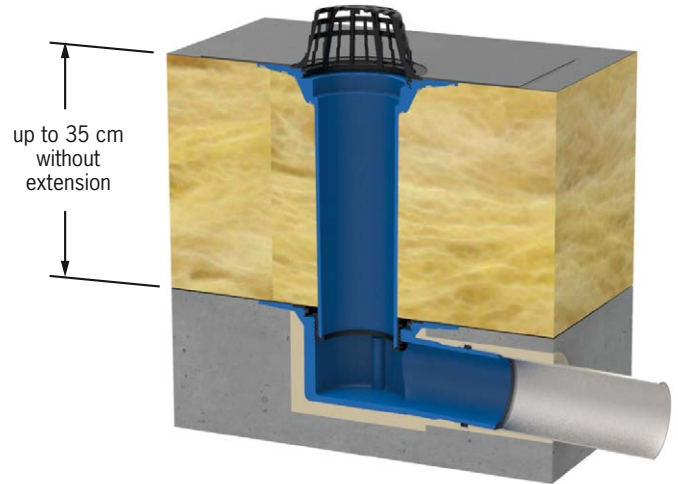

Compact collar drain horizontal DN 100 with extension element in an insulated roof (up to 35 cm without extension)

Technical data compact collar drains

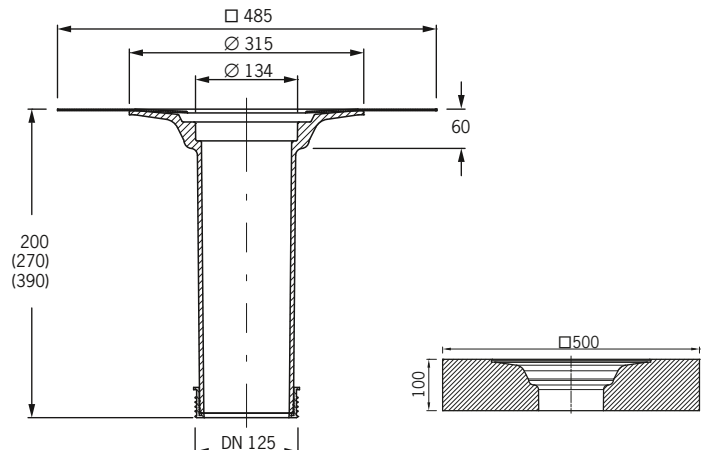
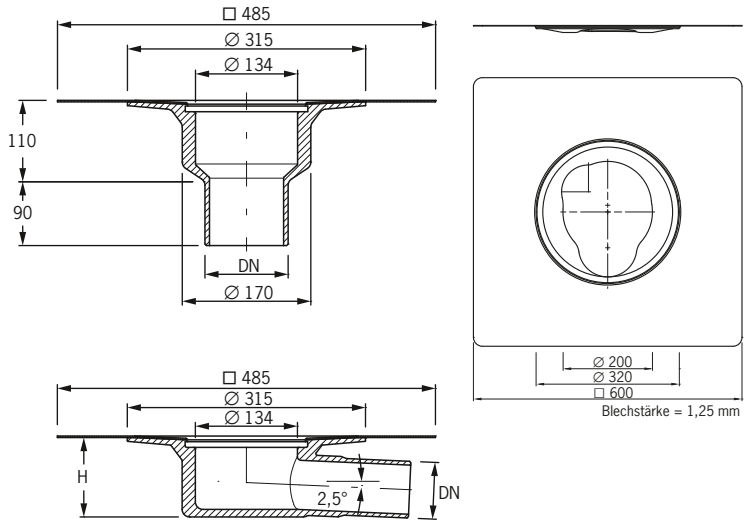

*Drainage capacity acc. to DIN EN 12532 in l/sec (accumulation height in millimeter/s)