

Stainless Steel Drain

The indestructible one



Horizontal stainless steel drain with corresponding extension element

The Grumbach stainless steel drain

- the robust, non-flammable drain series made of rust free stainless steel
- available in three nominal widths DN 50, 70 or 100
- with fastening holes in the fixed flange for secure fastening to the surface
- absolutely back-flow secure due to a sleeve connection
- due to the flange press seal and clamp, any extendable roof seal can be connected securely
- high stability and drainage capacity
- due to its attractive appearance it can also be used as an Attika emergency overflow
- due to its special construction (without pot, long supports) it is easy to assemble and also a good choice as a redevelopment drain, among other things.

Installation example und technical data stainless steel drain

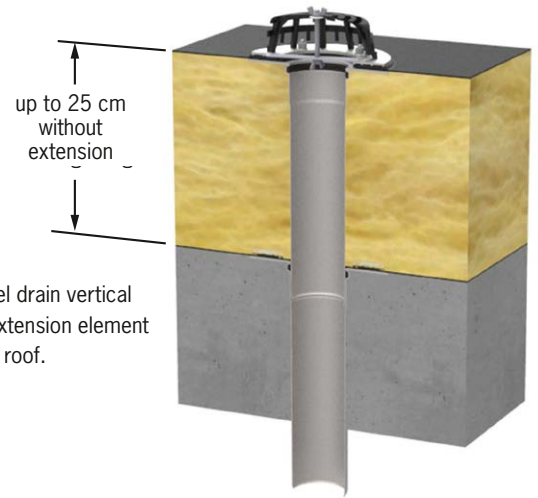

Stainless steel drain vertical DN 70 with extension element in a insulated roof.



Stainless steel drain horizontal DN 70 in a ventilated roof

Dimension Art. No.
Stainless steel drain vertical DN 50 2600 DN 70 2602 DN 100 2604
Stainless steel drain horizontal: DN 50 2611 DN 70 2612 DN 100 2614
Extension element made of stainless steel DN 50 2680 DN 70 2682 DN 100 2684

Art.	DN	d1	d2	H	H1	H2	X	T	Drainage capacities*
2600, 2680	50	50	65	45	-	-	150	-	1,5 l/s (35 mm)
2602, 2682	70	75	90	55	-	-	190	-	3,5 l/s (35 mm)
2604, 2684	100	110	125	65	-	-	240	-	5,1 l/s (35 mm)
2611	50	50	-	38	81	106	150	170	2,0 l/s (35 mm)
2612	70	75	-	50	112	150	190	210	4,1 l/s (35 mm)
2614	100	110	-	55	133	188	240	260	5,2 l/s (35 mm)

Technical data stainless steel drain

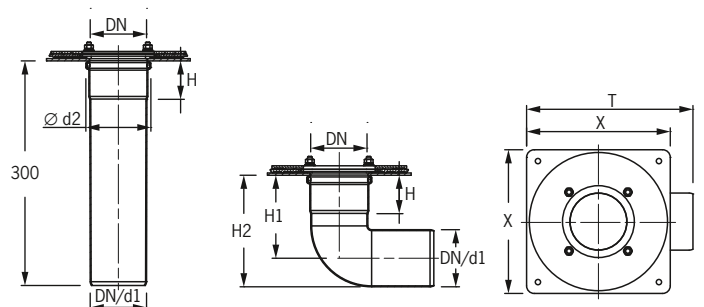

The stainless steel drains are non-flammable acc. to DIN 4102 (Fire protection class A1).

*Drainage capacity acc. to DIN EN 1253-2 in l/sec (accumulation height in millimeters)